

Type 2 AC power Surge Protector DS40

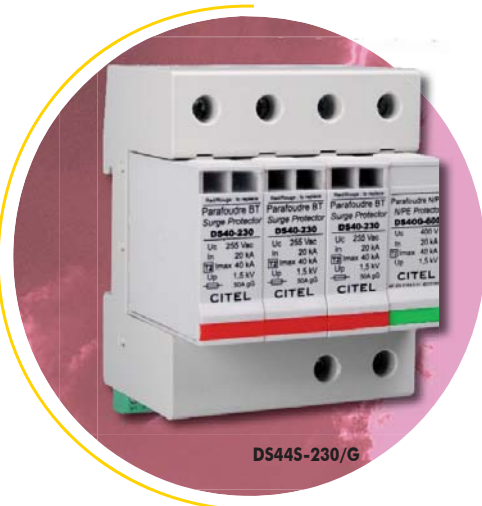

DS44S-230/G

DS40 Type 2 AC Surge Protectors are used mainly for primary protection of single and 3-Phase networks at the main electrical panel. They provide common-mode (between L and PE) or common and differential mode (L/PE and L/N) when associated with DS40G (DS4x-xxx/G version). They are available in one-phase, single-phase, three-phase, and three-phase+neutral versions.

The DS40 impulse discharge capability classifies this SPD as regular Type 2, useful in case of medium lightning density areas. IEC60364 standard requests Type 2 SPD at the entrance of installation if the keraunic level $N_k > 25$.

This SPD is based on high energy varistor equipped with thermal disconnector and failure indicator, to comply with standards. Version with a remote signaling for disconnection indication is also available (DS4*S).

The DS40 is available for a large range of AC voltages. The DS40 is DIN rail compatible and is built with a plug-in module (DSM40-xxx) and a fixed base, which allows an easy and fast maintenance.

- **Type 2 AC Surge Protector**
- **Discharge currents : I_n : 20 kA / I_{max} : 40 kA**
- **Pluggable module for each phase**
- **Remote signaling option**
- **IEC 61643-1 and EN 61643-11 compliance**

Dimensions (in mm)

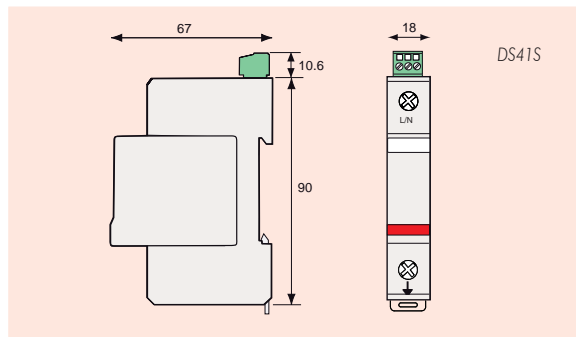

Electrical diagram

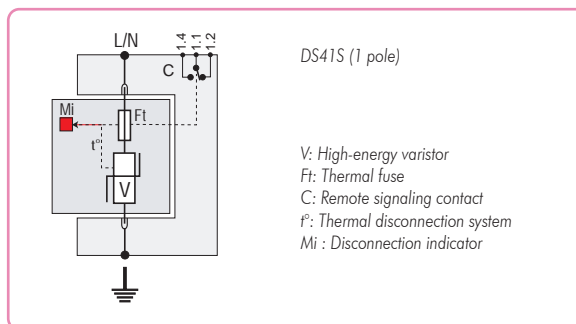

Characteristics

CITEL part number	DS41-400	DS41-230	DS41-120
Network	230/400V	230/400V	120/208V
Max. operating voltage	U_c 400 Vac	255 Vac	150 Vac
Temporary overvoltage withstand	U_T 400 Vac	255 Vac	150 Vac
Operating current	I_c < 1 mA	< 1 mA	< 1 mA
Leakage current at U_c			
Follow current	I_f none	none	none
Nominal discharge current	I_n 20 kA	20 kA	20 kA
15 x 8/20 μ s impulse			
Maximum discharge current	I_{max} 40 kA	40 kA	40 kA
max. withstand 8/20 μ s			
Protection level (at I_n)	U_p 1.8 kV	1.25 kV	0.9 kV
Residual voltage at 10 kA	1.5 kV	1.1 kV	0.7 kV
Residual voltage at 5 kA	1.3 kV	0.9 kV	0.6 kV
Admissible short-circuit current	25000 A	25000 A	25000 A
Associated disconnection devices			
Thermal disconnector	internal		
Fuses	Fuses type gG - 50 A max. (see Note 1)		
Installation ground fault breaker	Type «S» or delayed		
Mechanical characteristics			
Dimensions	see diagram		
Connection	by screw terminals : 4-25 mm ² / by bus		
Disconnection indicator	1 mechanical indicator		
Remote signaling of disconnection	Option DS40S - output on changeover contact		
Mounting	symmetrical rail 35 mm		
Operating temperature	-40/+85 °C		
Protection class	IP20		
Housing material	Thermoplastic UL94-V0		
Standards compliance			
EN 61643-11	Europe	Low Voltage SPD - Class II Test	
IEC 61643-1	International	Low Voltage SPD - Class II Test	
NF EN 61643-11	France	Parafoudre Basse Tension - Essais Classe II	
UL1449 ed.2	USA	Low Voltage TVSS	

Note 1: Rating in compliance with nominal discharge current. In order to increase service continuity, higher rating can be used (up to 125 A). For further information, please consult product instructions.



Type 2 AC power Multipolar Surge Protector

DS42

DS43

DS44

Dimensions and Diagram

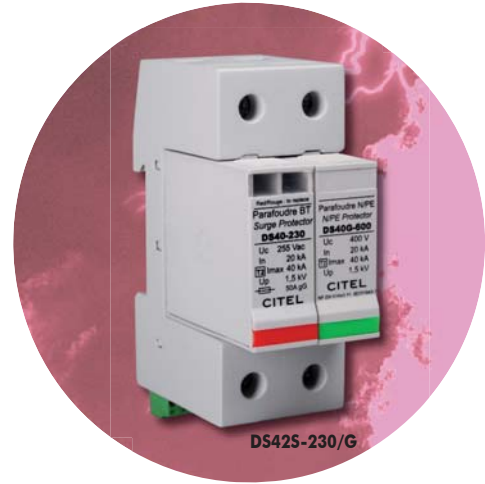
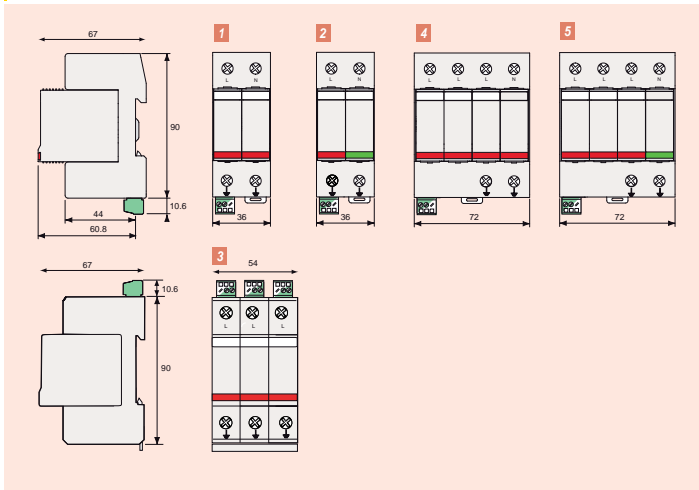

The DS40 surge protectors are designed to be used in a multipolar configuration to protect single-phase, 3-phase or 3-phase+neutral AC networks. They are sometimes associated with dedicated N/PE surge protector based on gas tube technology (DS40G).

2 possible configurations :

Common mode : CT1 configuration

DS40 surge protectors are connected between line(s), Neutral and protective wire (PE).

Common and Differential mode : CT2 configuration

DS40 surge protectors are connected between line(s) and Neutral to provide differential mode protection. A specific surge protector DS40G is connected between Neutral and Protective wire (PE) for common mode protection. This configuration provides the highest efficiency.

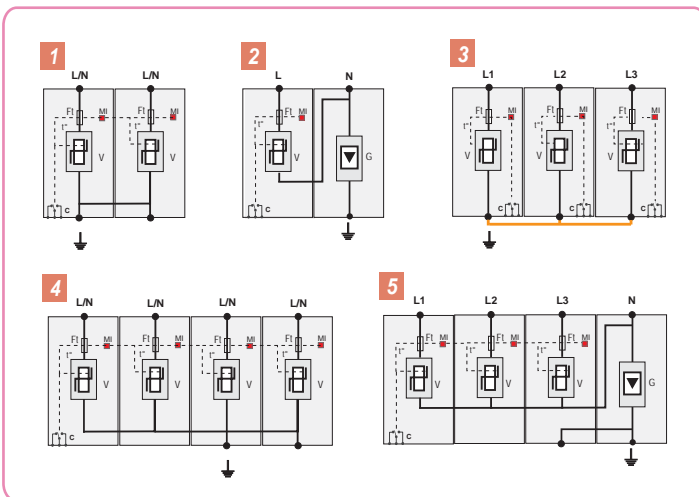

Part Number	Network	AC system	Protection mode		Imax total	Up L/PE	Up L/N	Diagram
			common	differential				
DS44-230/G	230/400 V 3-phase+N	TT-TN	●	●	40 kA	1.5 kV	1.25 kV	5
DS44-120/G	120/208 V 3-phase+N	TT-TN	●	●	40 kA	1.5 kV	0.9 kV	
DS44-400	230/400 V 3-phase+N	IT	●		160 kA	1.8 kV	-	4
DS44-230	230/400 V 3-phase+N	TN	●		160 kA	1.25 kV	-	
DS44-120	120/208 V 3-phase+N	TN	●		160 kA	0.9 kV	-	
DS43-400	400 V 3-phase	IT-TT-TNC	●		120 kA	1.8 kV	-	3
DS43-230	400 V 3-phase	TNC	●		120 kA	1.25 kV	-	
DS43-120	208 V 3-phase	TNC	●		120 kA	0.9 kV	-	
DS42-230/G	230 V Single phase	TT-TN	●	●	40 kA	1.5 kV	1.25 kV	2
DS42-120/G	120 V Single phase	TN	●	●	40 kA	1.5 kV	0.9 kV	
DS42-400	230V Single phase	IT	●		80 kA	1.8 kV	-	1
DS42-230	230V Single phase	TN	●		80 kA	1.25 kV	-	
DS42-120	120 V Single phase	TN	●		80 kA	0.9 kV	-	

*) or DS4x-320x (e.g: DS44-320/G) in case of possible temporary voltages (bad quality AC voltage or supply by AC generator set).