



CITEL



Ultra Compact Type 2+3 hard wired surge protector for class II

MLPX2-230L-W

- Ultra compact Type 2+3 hard wired surge protectors
- Wall mounting and hard wired connection
- Bracket breakable
- Protection rating : IP67
- Disconnection signaling by indicator
- AC disconnection in case of end of life
- EN 61643-11, IEC 61643-11 and UL1449 ed.5 compliance

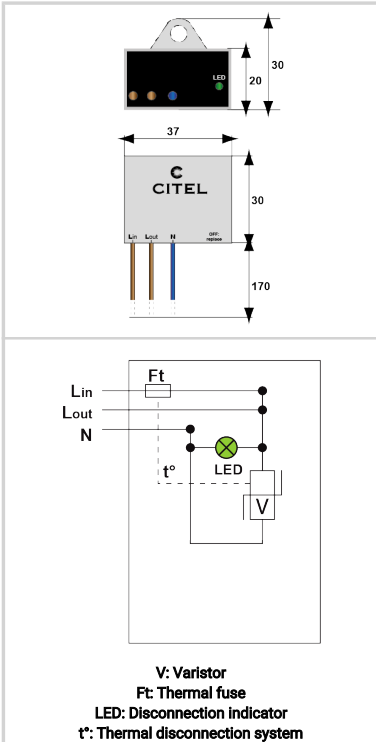

Electrical Characteristics		
SPD type	IEC	2+3
Network		220-240 V Single-phase
AC system		TT-TN
Nominal line voltage	Un	230 V
Max. AC operating voltage	Uc	320 Vac
Max. load current @25°C	IL	10 A
Temporary Over Voltage (TOV) Characteristics - 5 sec. <i>Without disconnection</i>	UT	335 Vac withstand
Temporary Over Voltage (TOV) Characteristics - 120 mn <i>Without disconnection or with safety disconnection</i>	UT	440 Vac disconnection
Residual Current <i>Leakage current to Ground</i>	Ipe	None
Nominal discharge current <i>15 x 8/20 μs impulses</i>	In	5 kA
Max. discharge current <i>max. withstand @ 8/20 μs by pole</i>	Imax	10 kA
Total Maximum discharge current <i>max. total withstand @ 8/20 μs</i>	Imax Total	20 kA
Withstand on Combination waveform IEC 61643-11 <i>Class III test: 1.2/50μs - 8/20μs</i>	Uoc	10 kV
Withstand on overvoltages IEEE C62.41.1		10 kV / 10 kA
Protection mode(s)		Differential Mode
Protection level L/N <i>@ In (8/20μs)</i>	Up L/N	1.5 kV
Admissible short-circuit current	Iscrr	10 000 A
Mechanical Characteristics		
Technology		MOV+GDT
Connection to Network		By wires: 1.5mm ² (L/N) and 2.5mm ² (PE)
Mounting		Wall or plate
Housing material		Thermoplastic UL94 V-0
Operating temperature	Tu	-40/+85°C
Protection rating		IP67
Failsafe mode		Disconnection and AC line cut-off
Disconnection indicator		LED green OFF and AC network cut-off
Operating indicator		Green Led ON
Dimensions		See diagram
Weight		0.045 kg
Disconnectors		
Thermal disconnector		Internal
Installation ground fault breaker		Type 'S' or delayed
Standards		
Standards compliance		IEC 61643-11 / EN 61643-11 / UL1449 ed.5
Certification		CB
Part number		
711217		

