



CITEL

1-pole Type 1 and Type 2 SPD for 48 Vdc

DDC30S-20-65



- › Combined SPD for DC supplies, 2-pole
- › Type 1 + 2
- › In: 15 kA / I_{max}: 30 kA
- › I_{limp}: 4 kA
- › Pluggable module
- › Remote signaling
- › prIEC 61643-41 compliance

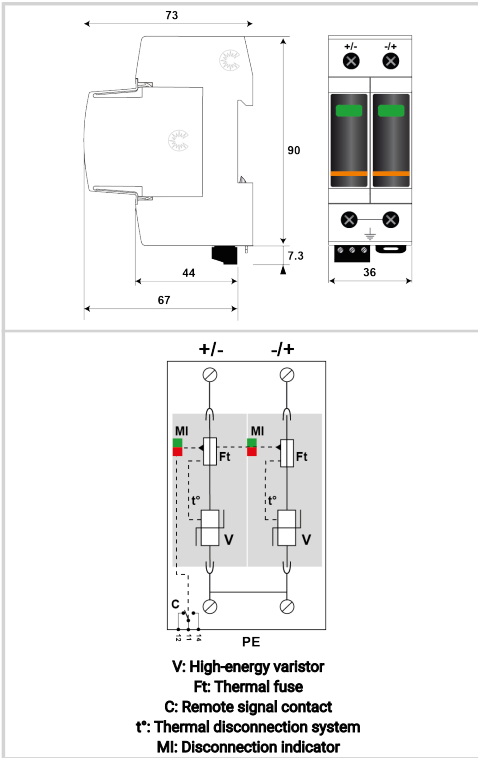

Electrical Characteristics		
SPD type	IEC	1+2
Nominal DC voltage	Un-dc	48 Vdc
Max. AC operating voltage	Uc	50 Vac
Max. DC operating voltage	Uc	65 Vdc
Residual Current	I _{pe}	< 0.2 mA
Leakage current to Ground		
Follow current	I _f	None
Nominal discharge current	I _n	15 kA
15 x 8/20 μs impulses		
Max. discharge current	I _{max}	30 kA
max. withstand @ 8/20 μs by pole		
Impulse current by pole	I _{limp}	4 kA
max. withstand 10/350μs by pole		
Total lightning current	I _{total}	8 kA
max. total withstand @ 10/350μs		
Connection mode(s)		+/-PE and -/PE
Protection level +/-PE (-/PE)	U _p	300 V / 600 V
@ I _n (8/20μs)		
Admissible short-circuit current	I _{sc}	50 000 A
Mechanical Characteristics		
Technology		MOV
SPD configuration		2-poles
Connection to Network		Srew terminals: 2.5-25mm ² +/-: 1.5-10mm ²
Mounting		Symmetrical rail 35 mm (EN 60715)
Housing material		Thermoplastic UL94 V-0
Operating temperature	T _u	-40/+85°C
Protection rating		IP20
Failsafe mode		Disconnection from DC network
Disconnection indicator		2 mechanical indicators - Red/Green
Spare module(s)		MDDC30-65
Remote signaling of disconnection		Output on changeover contact
Wiring for remote signaling		1.5 mm ² max.
Max. Voltage/Current for remote signaling		250 V / 0.5 A (AC) / 30 V / 3 A (DC)
Dimensions		See diagram - 2TE (EN43880)
Weight		0.170 kg
Disconnectors		
Thermal disconnector		Internal
Back-up protection device		50 A min. - 125 A max. - Fuses Type gG
Standards		
Standards compliance		prIEC 61643-41
Part number		
828110122		

